

Control Systems for Machines, Processes, Buildings and Transport



Teco a.s. Introduction

Dear customers

Let us introduce ourselves:

Teco a.s. as a Czech Company offers you 35 years' experience with development and production of control systems for machines, processes, buildings and transport.

Our control systems have been reliably working in more than 30 countries worldwide. Due to our constant development in accordance with the newest technologies our products allow effective control and automation at the highest level.

We are one of leading Czech producers of PLC control systems (Programmable Logic Controller). We develop, manufacture and test systems according to international standard IEC EN 61131.

We guarantee long-term lifetime of our products, compatibility of control systems and full technical support. We manufacture spare parts for each system at least 10 years after finishing manufacturing of each control system generation.

We ensure high quality of our products and manufacturing processes in accordance with EN ISO 9001 standard. We also

achieve the highest quality with consistent product testing in own test facilities.

We reach permanent innovations by our strong development team and manufacturing capabilities. It allows us to hold long-term compatibility of all our control systems.

We are a member of company group that contains the development, manufacturing, distribution and application capabilities: GEOVAP (SCADA/HMI Reliance development) – Teco (PLC development and manufacturing) – Proteco (engineering, system integration, project applications) – Tecont (engineering, system integration, project application).

We deliver our products on the market through applicators, system integrators, design and distribution companies.

We provide to our customers a consulting, advising, technical support and hotline services.

We regularly train our customers, application and design companies and system integrators.



Milestones of the company

- 1919: B. K. Prchalove – telephone and telegraph device manufacturing
- 1934: Prchal-Ericsson & Co. – automated telephones and telegraph switchboards manufacturing
- 1945: Integration of Prchal-Ericsson & Co. into TESLA company
- 1966: Development and manufacturing of the first NC control system
- 1976: Development and manufacturing of the first generation PLC control system
- 1989: Development and manufacturing of new generation PLC under the name Tecomat NS940
- 1993: Teco foundation from Industrial Automation Division of TESLA company, beginning of new control system Tecomat NS950 manufacturing
- 1994: Transformation of the Teco company to join-stock company
- 1997: Development and manufacturing of Tecoreg regulation systems and Tecomat TC600 PLC series
- 2003: Development and manufacturing of Tecomat TC700 – new generation of modular PLC
- 2007: Development and manufacturing of Tecomat Foxtrot – the latest generation of the compact PLC from Teco



Fields of applications



Processes

galvanization lines, chemical and petrochemical industry, furnaces, annealing processes, glass casting, cement works, brick works, concrete plants, vulcanisation, dust exhaust, mills, malting plants, bakeries, breweries, water treatment plants, sewage treatment plants, sanitation service companies, feeding mixture production plants, boiler houses, heat exchange stations, power engineering, switching stations, substations, consumption optimisation, gas distribution



Machines

production lines, presses, compressors, forming machines, separating machines, cranes, winding machines, testers, rolling mills, wood processing industry, meat packing plants, bioreactors, stock control, small water power stations, wind power stations



Buildings

building management, air conditioning, boiler rooms, cogeneration units, biomass combustion, swimming pool technologies, clean rooms, remote control, vizualisation



Transport

tunnel control systems, transportation systems, tractions, telematics, trams, trains, cableways, subways, navigation, variable information systems, changing traffic signs

Key customers, key contracts

- Kapsch s.r.o.
- AŽD Praha, s.r.o.
- Black Sea Terminal (Socar Azerbajdžan)
- ČEZ, a.s.
- PRE a.s. (Pražská energetika)
- České dráhy, a.s. (Czech Railways)
- Ředitelství silnic a dálnic ČR/ Road and Motorway Directorate of the Czech Republic
- Škoda Auto, a.s. Mladá Boleslav
- Třinec Ironworks, a.s.
- Vítkovice–Tube rolling mill, a.s.
- Škoda Plzeň, a.s.
- OKD a.s. Ostrava
- Dopravní podnik hl.m. Prahy, a.s.
- Dopravní podnik města Brna, a.s.
- Aliachem, a.s., o. z. Synthesia Pardubice
- Paramo, a.s., Pardubice
- International Power Opatovice, a.s.
- Small water power plants in the Czech Republic, Slovak Republic, Poland, Germany, Japan
- Jihočeská plynárenská, a.s.
- Plzeňský prazdroj, a.s.
- Pražské Pivovary, a.s., Staropramen
- Budějovický Budvar n.p. České Budějovice
- Pepsi Cola, a.s., Praha
- Obchodní sladovny, a.s., Nymburk
- Master Foods k.s. Poříčí nad Sázavou
- Masokombinát Schneider Plzeň
- Masokombinát Váhala Hustopeče nadBečvou
- Sewage treatment plant in Hranice na Moravě
- Sewage treatment plant in Žďár nad Sázavou
- National castle Karlštejn
- Moravian regional library in Brno
- Panasonic Pardubice
- Swimming pool Ústí nad Orlicí
- Hospital in Přerov
- Ahold ČR, a.s.
- Dalkia, a.s., Ostrava
- Central heating system of town Varnsdorf
- Central heating system of town Bruntál
- Central heating system of town Bystřice nad Pernštejnem
- Central heating system of town Rychnova nad Kněžnou
- Central heating system of town Pardubice
- Nicosia Water Board – Larnaca – Kypr
- Martinská Teplárenská, a.s., Slovensko
- Czech Technical University Praha
- National Gallery Praha
- Visteon Autopal, s.r.o., Nový Jičín
- PAL Kbely
- KM Beta Kyjov
- Cement Hranice, a.s.
- Cableway to Petřín
- Funiculars in the Czech Republic, Slovak Republic, Poland, Russia
- Enika Łódź tramvaje Polsko
- Zakłady Górnicze Rudna – Polska Miedz Polkowice

Foxtrot

Tecomat Foxtrot is a compact modular control and regulation system with powerful processor, mature communications, original two-wires and wireless connection with intelligent electroinstallation elements and peripherals.

Foxtrot in Ethernet network – LAN/WAN/internet

Foxtrot is based on modern and perspective Ethernet communication. There is integrated FAST ETHERNET 100Mbit/s with RJ-45 connector and it enables direct integration of PLC Foxtrot into standard and industrial Ethernet network. On this fast communication line Foxtrot holds up to 6 connections, for instance with software Mosaic, SCADA visualization system, OPC server, graphical touch panel and concurrently answers to 6 web clients questions to built-in web pages.

Foxtrot and extension modules on CIB bus

Foxtrot is perfectly designed to control intelligent electroinstallations and buildings. For this Foxtrot uses electroinstallation bus CIB – Common Installation Bus with guaranteed response between sensor and actuator to 150 ms. For this bus there is available still expanding amount of modules for interiors in the wall switch and sockets leading manufacturers designs, further modules for the installation into electroinstallation boxes, into lights and under covers of other device as well. Finally there are modules for installation on DIN rail into switchboards like circuit breakers etc.

Foxtrot in mobile network GSM/GPRS/EDGE/UMTS/3G/HSDPA

There are two options how to connect Foxtrot into mobile network. The traditional RS-232 connection is used for receiving and sending SMS messages or dial-up connection through AT commands. The progressive way uses GPRS/3G routers connected through Ethernet channel. It allows to use all Foxtrot's tricks, going out of its abilities to communicate direct with IP protocols, like time synchronization with internet servers, direct SQL database storing, internal web pages providing, downloading files stored at high capacity SDHC/SD/MMC cards, sending reports via e-mail etc.

Foxtrot and connecting with audio/video multimedia systems Control 4, Bang&Olufsen and others

Foxtrot is ready to communicate on fast ethernet channel and this allows to connect Foxtrot with nontraditional operator interface – multimedia audio/video systems. One of them is Control 4, another one is Bang&Olufsen. These systems are usually called multiroom systems and allow us to control, choice and distribute audio/video signals from any source to any place. By its control means typical for audio/video they are able to control lights, temperature and safety systems in buildings. And just for these typical functions of electroinstallation, metering, control and electronic safety systems, multiroom systems use Foxtrot for the connection with each element in the building – switch, light, heater, detector etc.



Important features

- High performance
- Modularity
- Installation design („circuit breakers“)
- Up to 270 inputs and outputs / 320 modules on CIB bus
- Built-in ethernet, web server, web pages
- On-line programming using Mosaic software
- Possibility of simple parameterization using FoxTool software
- Application software back-up in the internal memory
- Native Reliance 4 SCADA/HMI driver, Tecomat OPC server available
- SD/SDHC/MMC card slot as a high capacity storage mass up to 32 GB
- Support of Modbus RTU/TCP, Profibus DP, CAN, BACnet, HTTP and other standard protocols
- Program and communication compatibility with Tecomat TC700 and older Tecomat types

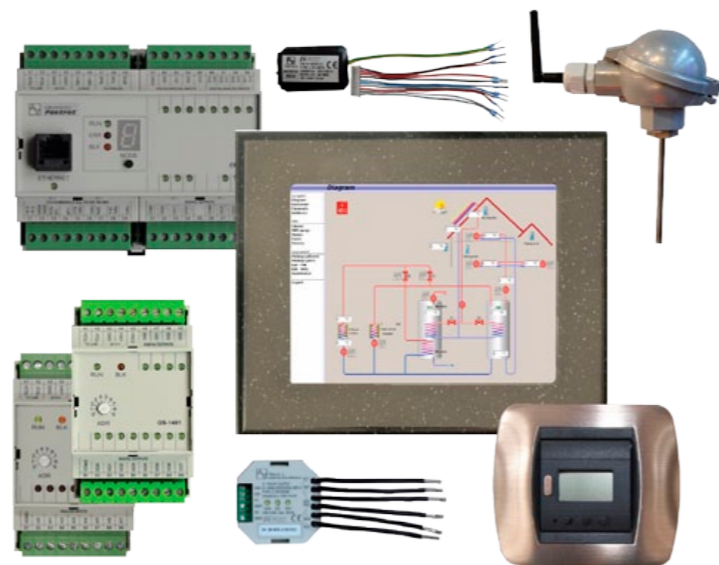

TC700

Tecomat TC700 is a top powerful modular control system of category PLC according to IEC EN 61131 standards for large scale of middle and large applications in industrial automation, process control, transport or building management systems. In redundancy connection it is perfect solution to applications with increased reliability.

Tecomat TC700 consists of:

- Frames of different size with internal serial bus and connectors
- Power supply with UPS function
- High performance central and communication modules with ethernet communication
- Large scale of peripheral modules for connecting all kinds sensors and actuators

Composition of Tecomat TC700 system:

Variability of Tecomat TC700 system helps user to manage middle complex tasks with modules placed in one frame as well as large systems with many inputs and outputs in multiple racks. If application needs, it is possible to create system with several large racks or large decentralized topology up to 128 modules, where each control node is created by less I/O.

Beside this, there are up to 10 serial communication channels operating in different modes and 2 independent ethernet ports, each with up to 18 independent logical connections in different communication modes.

Central module may operate in redundant connection including power redundancy and communication redundancy.

Important features of Tecomat TC700 system

- High performance and modularity
- CPU redundancy
- Up to 8000 inputs/outputs (analog and digital)
- Ethernet, USB, serial ports
- Web server, web pages
- On-line programming
- Application program back-up in the internal memory
- Software and communication compatibility with Tecomat Foxtrot and older Tecomat systems
- Inputs/Outputs exchange during operation (hot-swap)
- OPC server available
- Remote peripherals connection through optical cable
- Motion control up to 6 axis
- Power supply with UPS function
- Possibility to connect external modules with different kinds of integrated protection and switching circuits
- Modbus RTU/TCP, PROFIBUS DP, CAN, BACnet, HTTP



TC700 and Foxtrot application possibilities



For process control

- Function block libraries for advanced continuous control including auto tune controllers
- Direct connectivity of RTD and thermocouples
- Connectivity of intelligent sensors via HART protocol
- Communication with intelligent probes and analyzers via serial and Ethernet ports
- Frequency converters control via PROFIBUS protocol
- Comfortable debugging and maintenance of applications using a hot swap function of I/O modules or on-line programming
- Remote monitoring and programming through Ethernet/internet
- Redundant connection for the technologies requiring higher operational reliability



For machine engineering applications

- Control of up to 6 independent axes in various modes of motion coupling (Motion Control)
- High-speed inputs for a connection of incremental position sensors
- Period, pulse length and phase shift measuring for generator synchronization
- Support for industrial buses via various protocols (PROFIBUS DP, CAN, Modbus RTU/TCP)



For traffic control

- Mechanical design allowing the operation in the environment with impulses and vibrations
- Enhanced thermal endurance at extreme conditions
- Higher operational reliability thanks to redundancy functions of CPU, power supplies or communication
- Special FSK modems for safe long-distance information transfer (telematics)
- Measuring and control of all energy types consumption (Energy Management, substations)
- Integration of safety elements of traffic constructions



For building management systems

- Control of middle and larger technologies for heating, ventilation and air conditioning machine rooms
- Measuring and control of all energy types consumption (Energy Management)
- Integration of the building safety elements (Alarm/Fire-fighting systems)
- Integration of access control systems – doors, gates etc.
- Excellent building processes coordination
- Control optimization ensuring cost savings owing to lower consumption
- Support of TCP/IP and BACnet communication protocols

Tunnel control:

- Variable traffic signs, operational information devices, traffic detectors – speed measurement, vehicles weighing, accommodative and emergency lighting, ventilation, physical quantities measuring – opacity, sound systems, fire-fighting system, SOS announcing point, video supervision signalization

Control



Reliance 4 – visualization HMI/SCADA system



Telemetry, RTU function



Telematics, changing traffic signs control



Measuring and control, DDC function



Safety, access control

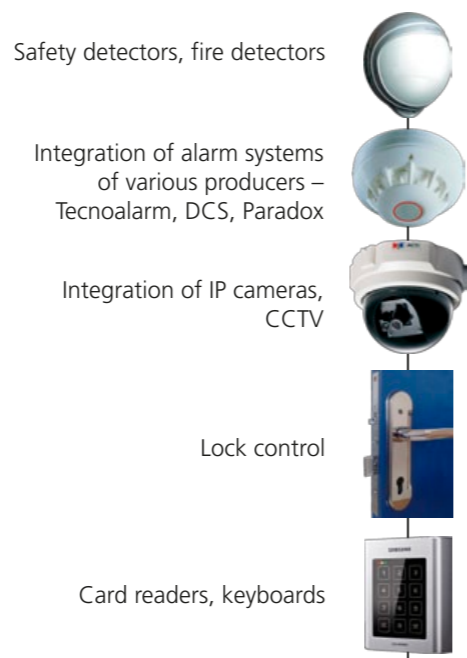

Internet / SMS / GPRS / UMTS – communication via mobile operators



Integrated Ethernet 100 Mbps



Up to 32 GB memory for data and web pages, datalogger

Connection with other control systems Tecomat Foxtrot and Tecomat TC700



- Lights, sockets switching
- LED, tubes, bulbs dimming
- Sunblinds, doors, gate control
- Zone heating, radiators, floor heating, fan-coils
- Air-conditioning control
- Ventilation, controlled recuperation
- Connection of heat pumps, solid fuel boilers
- Weather station
- Solar thermal and photovoltaic panels connection
- Irrigation, water consumption management
- Pool technologies
- Defrosting of outdoor areas
- Energy consumption measurement and control

Expansion via 2-wire installation bus CIB – Common Installation Bus

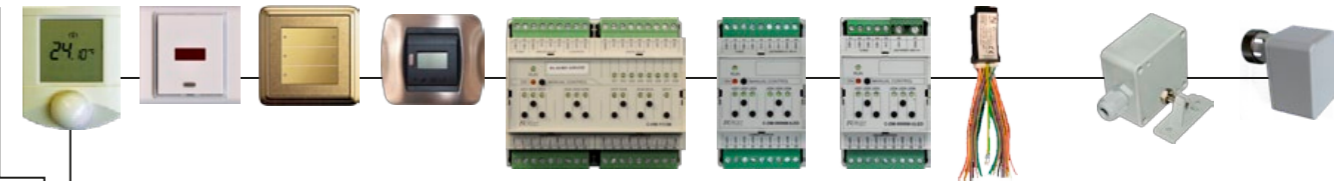

Expansion of inputs and outputs via quick system bus TCL2



Extending over the wireless network RFox



- ### Communication compatibility
- Frequency converters control
 - DC motors and step motors control (PWM)
 - Position measurement and control
 - Frequency and phase shift measurement
 - Built-in master Profibus DP
 - TCP/IP, UDP, e-mail sending, SMS
 - Modbus RTU, MODBUS TCP, BACnet
 - ASi bus for machinery applications

Racks of 4 different sizes

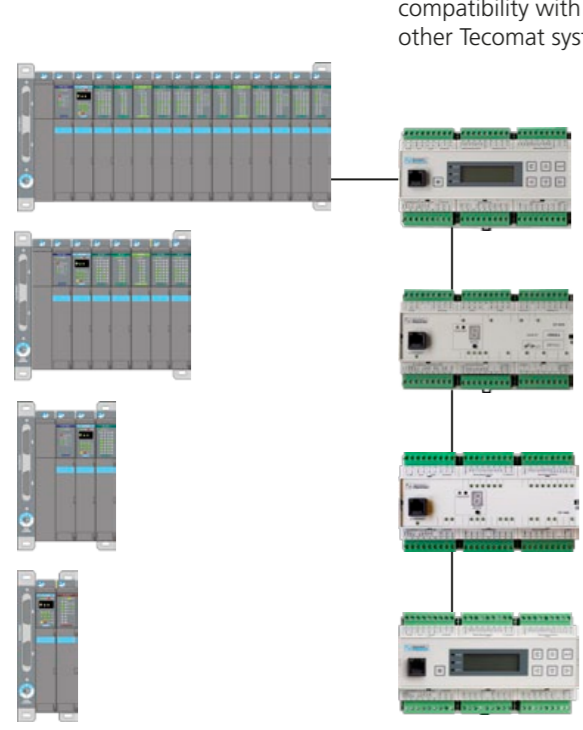

Communication compatibility with other Tecomat systems

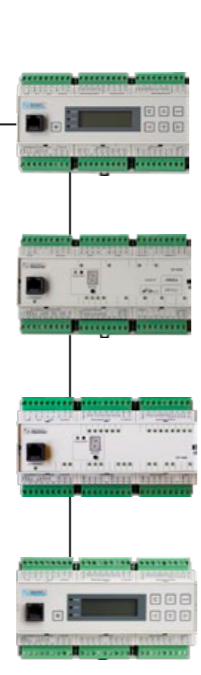

Operator panels over serial interface, textual, graphical

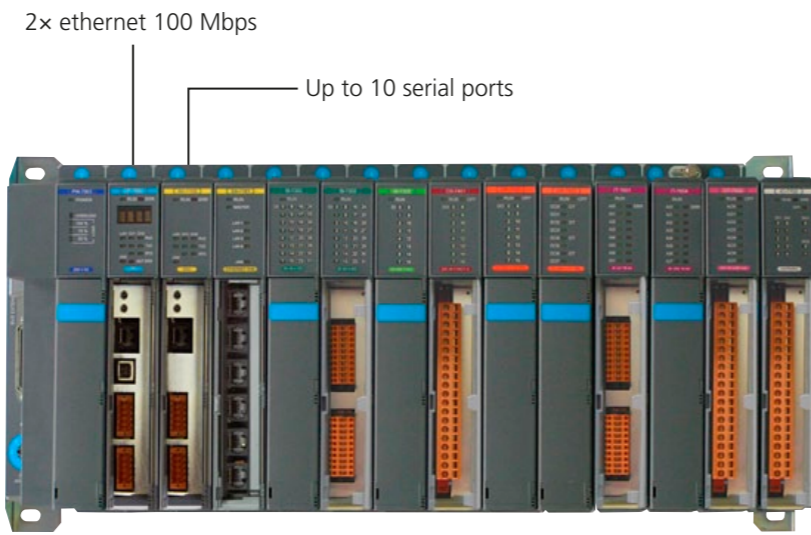

2x ethernet 100 Mbps

Up to 10 serial ports

Peripheral module hot-swap



External modules with terminals for I/O high density modules

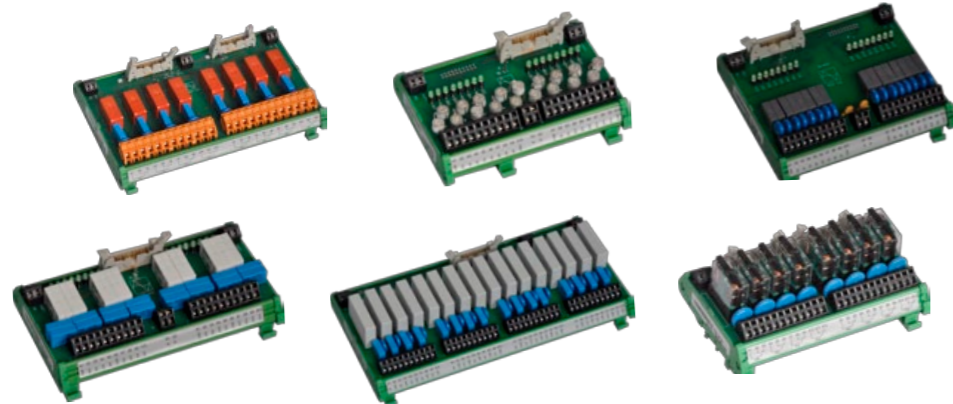

16-64x DI - digital inputs



8-64x DO - digital outputs

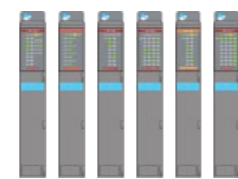

Power supply
230 VAC, 110 VDC, 24 VDC



Visualization via Ethernet interface - SCADA Reliance4

Wide range of communication submodules

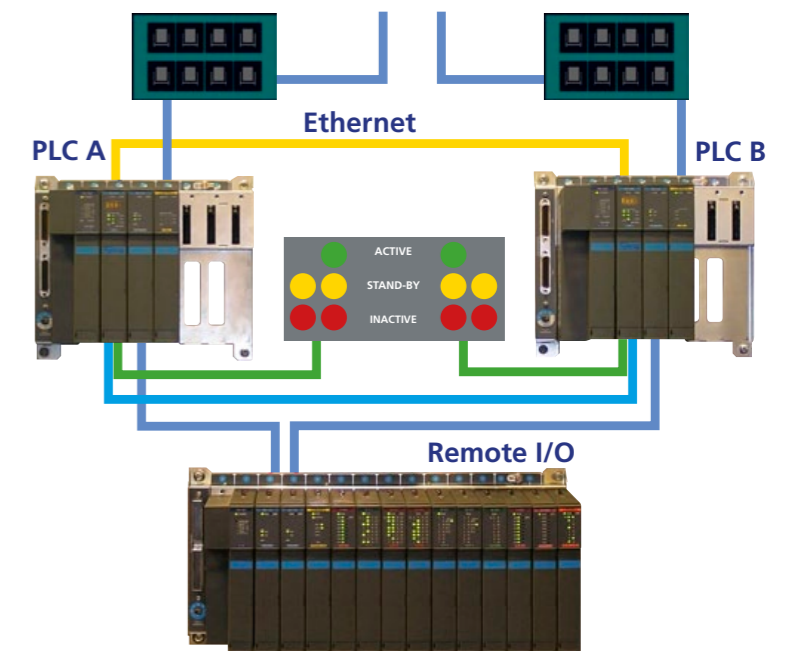
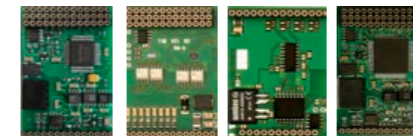

Expanded TC700 assembly with system expanders SE-7131 and SE-7132. Number of positions can be expanded up to 128.

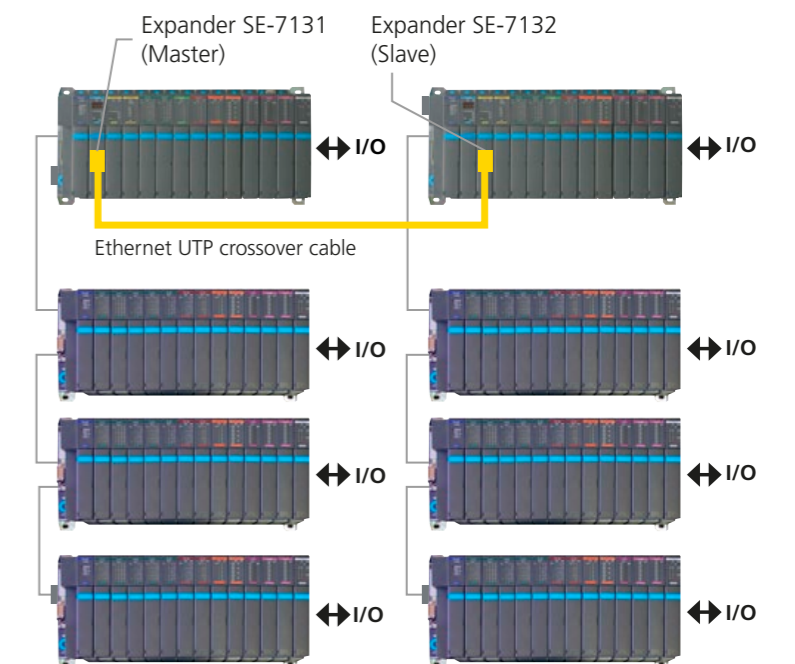

Selection of realized applications



Black Sea Terminal – management of oil transport routes – Poti, Georgia



Water stations and distribution network control – Nicosia Larnaca, Kypr



Heat and air-conditioning control system – Panasonic Czech Republic



Highway tunnel Valik control Czech Republic



Microclimate control of the Chapel of the Holy Cross National Castle Karlštejn, Czech Republic



Air conditioning control system – administrative center Ramat Gan – Tel Aviv, Israel



Automatic assembly line and output checking VW and Skoda – Shanghai, China



Control of central heating system – Martin Slovak Republic



35 MWp photovoltaic power plant control – Veprek Czech Republic



Communication among alarm devices and traffic control room – Prague Subway, Czech Republic



Mosaic

Mosaic is a complex development environment for programming of common as well as sophisticated applications of Te-comat systems. Mosaic allows easy creation and debugging of programs, either small or extensive projects involving a large number of control systems or remote I/O modules. Mosaic uses a wide range of modern technologies. The environment architecture and its single instruments respect the IEC61131-3 standard. Mosaic includes tools for creating web pages, operator panel screens, design and PID controller debugging, system diagnostics, data logging etc.

Important features:

- Programming according to IEC 61131-3 standards:
 - IL – Instruction List
 - ST – Structured Text
 - LD – Ladder Diagram
 - FBD – Function Block Diagram
 - CFC – Continuous Function Chart
- Function block libraries
- Project Manager – Project management
- WebMaker – Web page designing
- PanelMaker / GPMaker – for textual and graphical panels screen design
- GraphMaker – diagnostics, graphs
- PIDMaker – PID loop design and debugging
- System and network configuration
- PLCnet – data sharing configuration
- PLC and operator panel simulation
- On-line programming
- Datalogger



FoxTool

FoxTool is a simple and fast parameterization tool for intelligent electrical installations. You may set from your computer parameters of all typical functions in the intelligent house: lighting, shading, heating, cooling, air-conditioning, safety system, energy consumption control. FoxTool provides alarm reports and communication with user via PC or smart phone. Thanks to built-in central module simulator there is a possibility to make an application and debug it off-line.

Important features:

- Parameterization
- Project management
- Time schedule management
- SMS management
- Event management
- User communication (PC, SMS)
- Central module simulator
- Manager and Designer mode
- Possibility to import graphical objects
- Project web page designing



Reliance

The modern open SCADA/HMI system for real-time monitoring and operating of industrial technologies. By means of Reliance, it is possible to create graphical user interface between operated technology and the operator. Reliance is high-spectrum, secure and robust system, optimized even for very extensive applications.

Important features:

- Technology failure minimization via early service warning
- Data flow redundancy
- Subsequent analysis of failure or malfunction
- Continual data access (GSM, internet)
- Easy and transparent development environment
- Range of direct communication drivers
- OPC-client

Basic environment modules:

- Design
- View
- Control
- Control Server
- Server
- Web Client
- Mobile Client

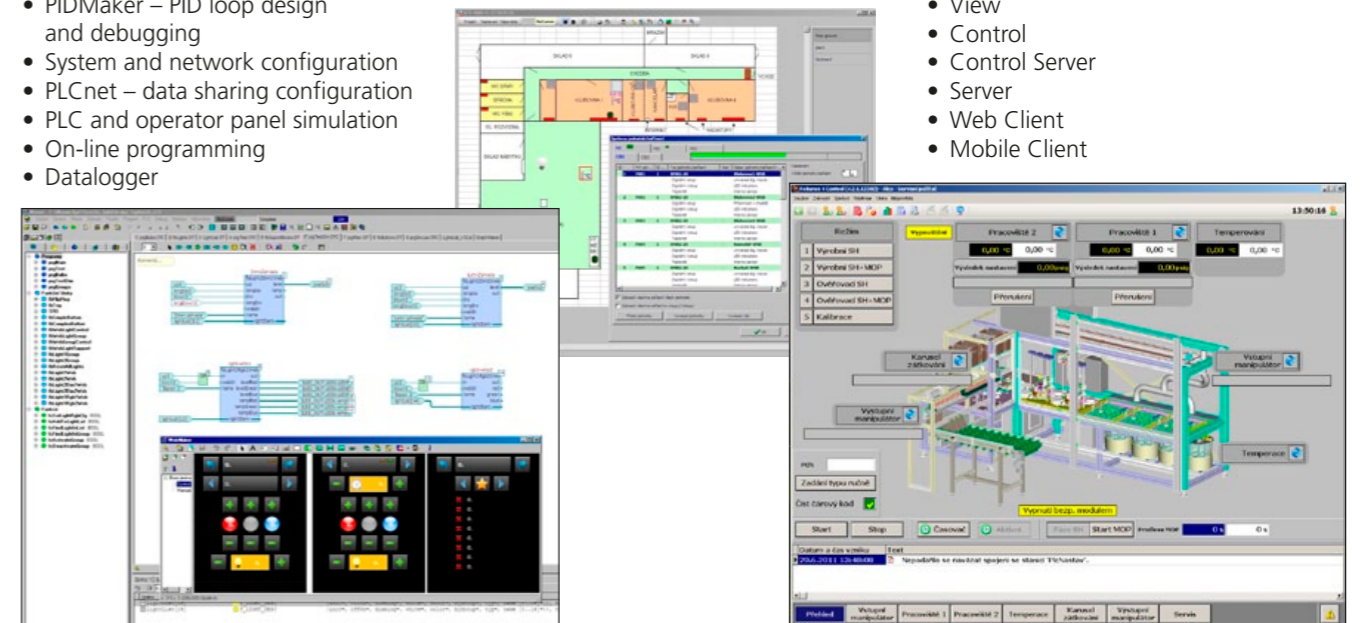

Dealerships

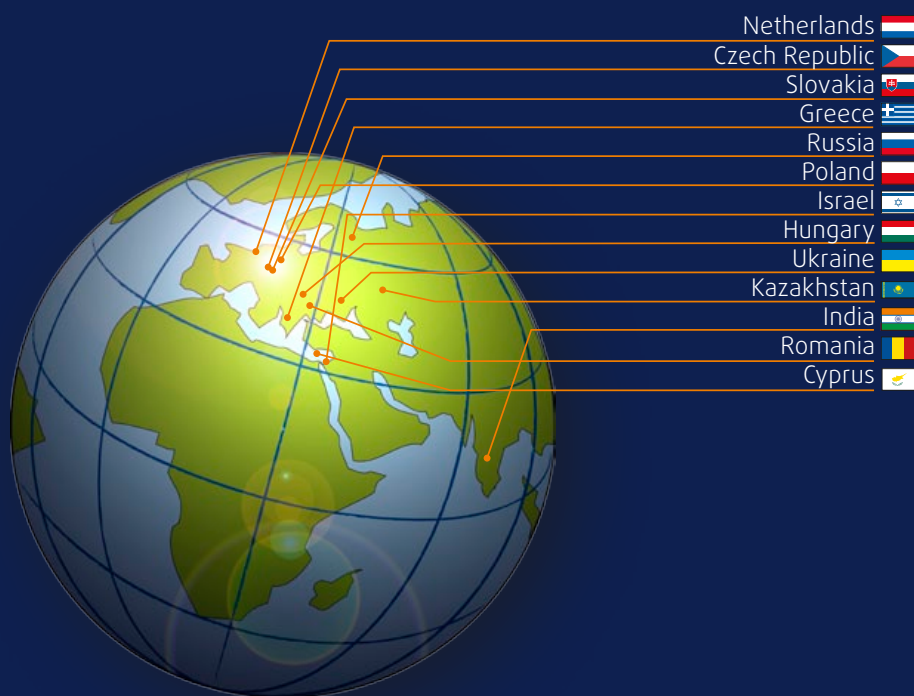

Netherlands 

Czech Republic 

Slovakia 

Greece 

Russia 

Poland 

Israel 

Hungary 

Ukraine 

Kazakhstan 

India 

Romania 

Cyprus 

Tecont s. r. o.

member of Teco Group
Jana Palacha 1552
532 35 Pardubice
Czech Republic
Phone: +420 466 310 650
Fax: +420 466 310 651
E-mail: tecont@tecont.cz
web: www.tecont.cz

Proteco s. r. o.

member of Teco Group
Teplého 1628
530 02 Pardubice
Czech Republic
Phone: +420 466 330 016
Fax: +420 466 330 024
E-mail: proteco@proteco.cz
web: www.proteco.cz

Geovap s. r. o.

member of Teco Group
Čechovo nábřeží 1790
530 03 Pardubice
Czech Republic
Phone/Fax: +420 466 024 111
E-mail: reliance@geovap.cz
web: www.geovap.cz

Slovteco s. r. o.

Teco authorised Partner in Slovakia
M. R. Štefánika 31/37, 977 01 Brezno
Slovakia
Phone/Fax: +421 486 113 147
E-mail: slovteco@stonline.sk
web: www.slovteco.sk

iQ House, s.r.o.

Teco authorised Partner in Slovakia
Turecká 36
940 61 Nové Zámky
Slovakia
Phone/Fax: +421 905 136 524
E-mail: info@iqhouse.sk
web: www.iqhouse.sk

PLCdirect Benelux B.V.

Teco authorised Partner in Benelux
Lorentzstraat 4b
NL-6716 AD EDE
Phone: +31 318 528 020
Fax: +31 318 540 708
E-mail: sales@plcdirect.eu
web: www.plcdirect.eu

B&R Design B.V.

Teco authorised Partner
Europasingel 19
7681 NA Vroomshoop
NEDERLAND
Office: +31 (0)546-646 025
Fax: +31 (0)546-646 028
E-mail: arjan@br-design.nl
web: www.br-design.nl

Teco Izrael

Authorised distributor
46230 Zisso, 23
Herzlyya city
Israel
Telefax: +972 99 580 882
Mobile: +972 548 116 200
E-mail: alex@tecomat.co.il
web: www.fiberoptic.co.il

Rhine Line Ltd.

Teco authorised Partner in Cyprus
1 Makariou Avenue
Mitsi Building III
Office 304
Nicosia 1065
Tel.: +357 22 757 146
Fax: +357 22 424 385
Email: info@rhine-line.com
web: www.rhine-line.com

PRETECH Automation Pvt. Ltd.

Teco authorised Partner in India
305, Poonam Plaza, Gultekdi,
Market Yard Road,
Pune - 411037, India
Phone/Fax: +91 20 24 267 956
E-mail: sales.pune@pretech.co.in
web: www.pretechautomation.com

EMEA Gateway

Teco authorised Partner in Poland
ul. Wilczej Łąki 9
03-159 Warszawa
Poland
Phone: +48 228 145 000
Fax: +48 224 869 753
E-mail: info@emeagateway.com
web: www.emeagateway.com

Szinusz Épületautomatika Kft

Teco authorised Partner in Hungary
6000 Kecskemét,
Selyem 18
Phone: +36 30 569 50 99
E-mail: info@automatizaltepulet.hu
web: www.automatizaltepulet.hu

BMS Automatizări Clădiri SRL

Teco authorised Partner in Romania
Cluj-Napoca, România
400635, str. Campina, no. 51-53
Phone: +40 722 154 003

HAFNER SRL

Teco authorised Partner in Romania
Iasi, jud. Iasi, Sos. Pacurari 92, România
Phone/Fax: +40 332 814 741
Phone: +40 745 124 198
E-mail: office@hafner.ro
web: www.hafner.ro

ЧП ПРОФИКОМ

Teco authorised Partner in Ukraine
ул. Кульпарковская 93 оф. 115
79021, г. Львов
Украина
Тел./Факс: +380 322 248 558
моб.: +380 679 589 603
E-mail: teco@i.ua

МАЭП 2000

Teco authorised Partner in Russia
Москва, Россия
Тел./факс: +7 495 781 26 51
E-mail: tecovent@mail.ru

I-home

Teco authorised Partner in Russia
ул. Халтуринская дом 6а
107 392 г. Москва
Тел./факс: +7 495 988 75 93,
+7 499 748 11 73
E-mail: mail@i-home.ru
E-mail: info@i-home.ru
web: www.i-home.ru

TOO „KazTECO“

Teco authorised Partner in Kazakhstan
10000 г. Астана
ул. Московская 3
Тел./факс: +7 717 294 98 51
Моб.: +7 701 523 04 21
E-mail: info@kazteco.kz
web: www.kazteco.kz